

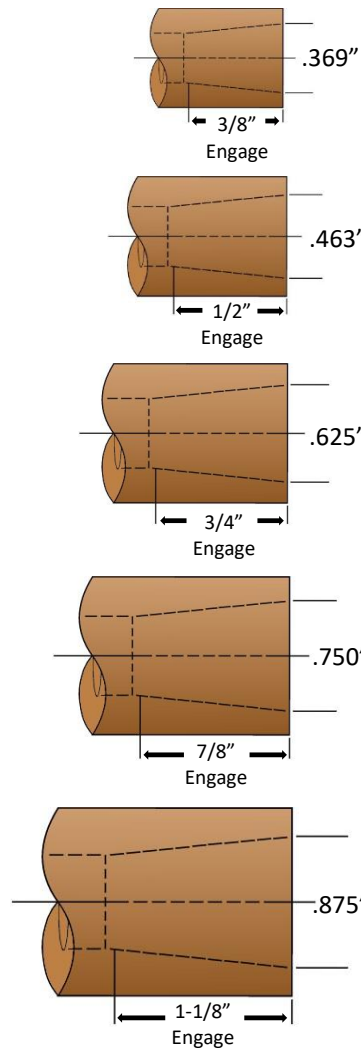

R.W.M.A STANDARD TAPERS



R.W.M.A.
#3
TAPER

R.W.M.A.
#4
TAPER
(OLD #1 MORSE TAPER)

R.W.M.A.
#5
TAPER
(OLD #2 MORSE TAPER)

R.W.M.A.
#6
TAPER

R.W.M.A.
#7
TAPER
(OLD #3 MORSE TAPER)

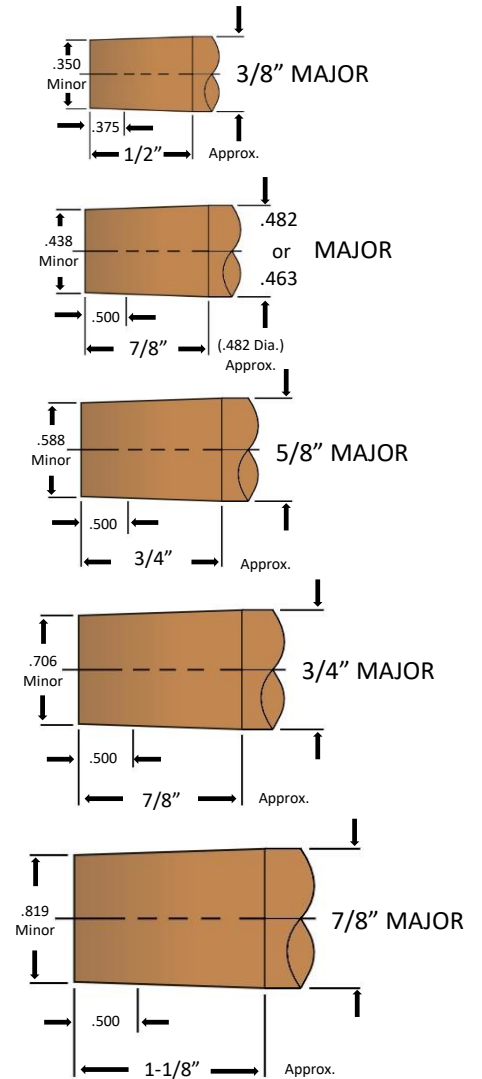

The above new R.W.M.A. tapers cover a broader range than the old Morse tapers. These new tapers are .600" taper per foot and replace the Morse tapers which vary from .5986 on the #1 M.T. to .6024 on the #3 M.T. The new R.W.M.A. #4, #5 and #7 tapers are inter-changeable with the old #1, #2 and #3 Morse tapers. You will note there are 2 new sizes, the #3 & #6 R.W.M.A. tapers.