



STUD & WELD NUT HEADS

Standard Weld Nut Pins

Nose Styles

Information required to order a standard weld nut pin:

- Series _____ (Select series 2, 3 or 4)
 Nose _____ (Select nose style A, B, C or D)
 E _____ " (Stamping hole dia. minus .005")
 F _____ " (Nut hole dia. minus .005")
 G _____ " (Stamping thickness)
 H _____ " (Nut thickness, including projections)



NOSE A



NOSE B



NOSE C

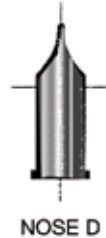

NOSE D

Application Sizes

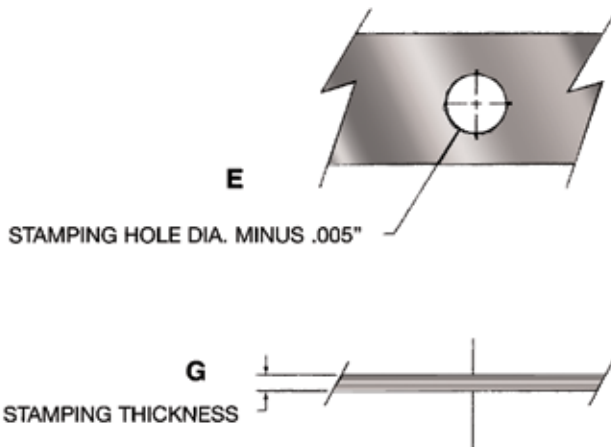

STAMPING HOLE DIA. MINUS .005"

STAMPING THICKNESS

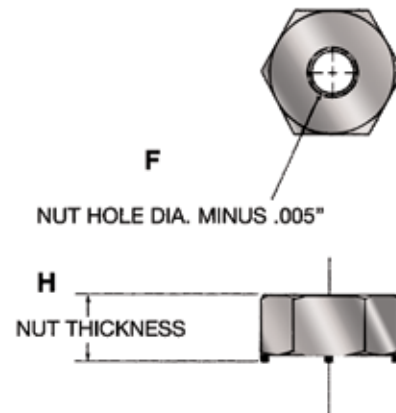

NUT HOLE DIA. MINUS .005"

NUT THICKNESS

NOTE: NUT THICKNESS INCLUDES PROJECTIONS

Standard Weld Nut Heads

Information required to order heads for stud welding applications:

- Stud Diameter or Thread Size _____
 Required Weld Face Diameter _____
 Series # _____

NOTE

Series Number	Max. Hole in Stamping*
2 (200 Series)	0.377 (9.58) ID
3 (300 Series)	0.627 (15.93) ID
4 (400 Series)	0.752 (19.10) ID

* Special weld nut electrodes are available for larger IDs and areas with clearance restrictions.

