

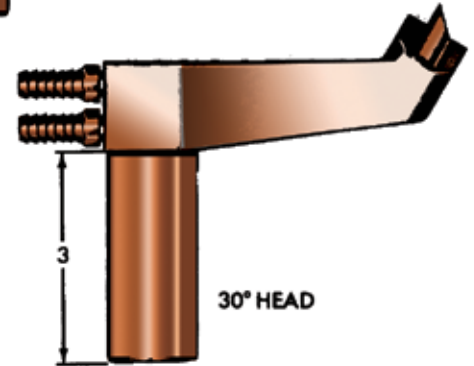

OFFSET WATER COOLED HOLDERS

STANDARD ELECTRODE HOLDERS OFFSET STYLE, EJECTOR AND NON-EJECTOR TYPES

Non-Ejector Holder No.	Shank Dia. Inches	RWMA Taper Size	Offset Inches	Taper Socket Angle (Degree)	Ejector Holder No.
ON-064-230	3/4	4	2	30	
ON-074-230	7/8	4	2	30	
ON-084-230	1	4	2	30	
ON-104-230	1-1/4	4	2	30	
ON-064-430	3/4	4	4	30	
ON-074-430	7/8	4	4	30	
ON-084-430	1	4	4	30	
ON-104-430	1-1/4	4	4	30	
ON-075-230	7/8	5	2	30	
ON-085-230	1	5	2	30	
ON-105-230	1-1/4	5	2	30	
ON-125-230	1-1/2	5	2	30	
ON-075-430	7/8	5	4	30	OE-075-430
ON-085-430	1	5	4	30	OE-085-430
ON-105-430	1-1/4	5	4	30	OE-105-430
ON-125-430	1-1/2	5	4	30	OE-125-430
ON-106-230	1-1/4	6	2	30	
ON-126-230	1-1/2	6	2	30	
ON-106-430	1-1/4	6	4	30	OE-106-430
ON-126-430	1-1/2	6	4	30	OE-126-430
ON-107-230	1-1/4	7	2	30	
ON-127-230	1-1/2	7	2	30	
ON-107-430	1-1/4	7	4	30	OE-107-430
ON-127-430	1-1/2	7	4	30	OE-127-430

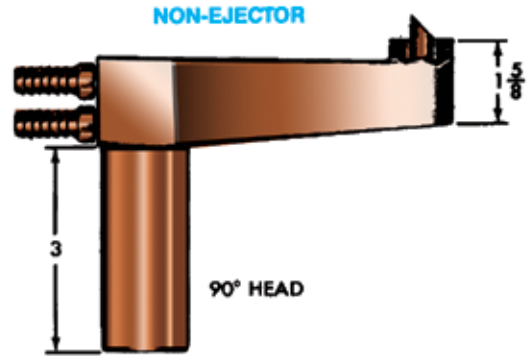

Non-Ejector Holder No.	Shank Dia. Inches	RWMA Taper Size	Offset Inches	Taper Socket Angle (Degree)	Ejector Holder No.
ON-064-290	3/4	4	2	90	
ON-074-290	7/8	4	2	90	
ON-084-290	1	4	2	90	
ON-104-290	1-1/4	4	2	90	
ON-064-490	3/4	4	4	90	
ON-074-490	7/8	4	4	90	
ON-084-490	1	4	4	90	
ON-104-490	1-1/4	4	4	90	
ON-075-290	7/8	5	2	90	OE-075-290
ON-085-290	1	5	2	90	OE-085-290
ON-105-290	1-1/4	5	2	90	OE-105-290
ON-125-290	1-1/2	5	2	90	OE-125-290
ON-075-490	7/8	5	4	90	OE-075-490
ON-085-490	1	5	4	90	OE-085-490
ON-105-490	1-1/4	5	4	90	OE-105-490
ON-125-490	1-1/2	5	4	90	OE-125-490
ON-106-290	1-1/4	6	2	90	OE-106-290
ON-126-290	1-1/2	6	2	90	OE-126-290
ON-106-490	1-1/4	6	4	90	OE-106-490
ON-126-490	1-1/2	6	4	90	OE-126-490
ON-107-290	1-1/4	7	2	90	OE-107-290
ON-127-290	1-1/2	7	2	90	OE-127-290
ON-107-490	1-1/4	7	4	90	OE-107-490
ON-127-490	1-1/2	7	4	90	OE-127-490

EJECTOR

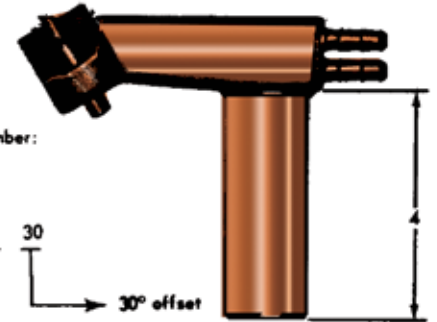
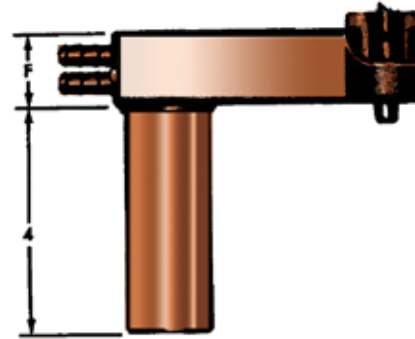

Explanation of holder code number:

Example: ON-105-230

